



Student Involvement

GUIDELINES FOR BOOTHS

BOOTH SPACE SELECTION

1. There will be a maximum of 28 booths allowed in the area at any one time.
2. A lottery system will determine which organizations may place a booth on campus during the semester.
3. The Booth Lottery will be conducted as follows:
 - a) Lottery participation forms are available in USU, Reservation Center Room 301; signed forms should also be submitted to the USU Reservations Center.
 - b) Lottery Participation Forms will be accepted until 12 noon on the last day of instruction for the semester preceding the one in which you desire a booth space.
 - c) The Booth Lottery drawing will be held each semester on the last day of instruction, at 12 noon (site to be determined).
 - d) A representative from your organization must be in attendance at the lottery drawing.
 - e) The first twenty-eight (28) organizations selected in the lottery drawing will receive a booth space for the following semester.
 - f) Selection of each specific booth space will take place immediately following the lottery. Space selection will be done in the order of lottery selection.
 - g) (UPDATED) Organizations may not move from one booth space to another during any semester.
 - h) Lottery selections are not transferable to any other organization.
 - i) All entries not selected for the twenty-nine (28) available spaces will be put on a waiting list in the order of drawing selection.
 - j) Any organization not participating in the lottery may be added to the waiting list on a first come, first serve basis.
 - k) All organizations participating in the lottery and placed on the waiting list will automatically receive one extra entry in the following semester's lottery if they choose to again participate.
 - l) If your organization is selected from the waiting list to bring a booth on campus within the first two (2) weeks of instruction, you will not receive an extra entry the following semester.
 - m) If your organization is selected from the waiting list to bring a booth on campus, you must bring the booth on campus within 3 days of notification, unless an exemption has been granted from the Reservations Center. Failure to do so will result in loss of the space.
 - n) If your organization loses its booth space for failing to meet minimum staffing requirements, your organization will be automatically excluded from the following semester's lottery.

BOOTH SET UP

1. Booths may be placed on campus after 5:30 p.m. on the Friday prior to the first day of instruction.
2. All booths must be placed on campus before the first day of instruction.
3. All booths must be placed within the marked space the organization has selected.

BOOTH MAINTENANCE

1. If any booth is defaced with graffiti, the booth's owner must remove the graffiti within five days.
2. No University tables and/or chairs may be used for staffing purposes. Failure to comply will result in a \$15 fee, per item.
3. All booths must be trash free by the end of each staffing day.

BOOTH STAFFING

4. (UPDATED) All organizations with a booth outside of the University Student Union will be required to staff their booth a minimum of 6 hours per week, during these hours:
 - Monday – Thursday, 9:00 a.m. - 7:00 p.m.
 - Fridays, 9:00 a.m. - 4:00 p.m.Organizations are not required to submit their coverage schedule to the Reservations Center but must fulfill the minimum 6 hours of coverage per week as noted in the Booth Coverage Log (see number 13).
5. (UPDATED) Booth Coverage Log: Organizations will be required to record booth hours at the USU Information Center (located on the main level of the University Student Union) during normal business hours:
 - Monday – Thursday, 9:00 a.m. - 7:00 p.m.
 - Fridays, 9:00 a.m. - 4:00 p.m.Please log in at the start and end time of each shift.
6. (UPDATED) Student Involvement staff will review log entries on a weekly basis to ensure that your organization has fulfilled the minimum 6 hour/week coverage requirement. Consequences for not meeting the 6 hour/week coverage requirement occur in three steps:
 - 1st strike a warning letter and a notice will be placed on the booth;
 - 2nd strike a second warning letter and a notice will be placed on the booth
 - 3rd strike a notification to immediately remove your booth from the area within 72 hours
7. (UPDATED) If your group anticipates you cannot meet the minimum 6 hours of coverage in any given week, please contact the Coordinator of Clubs & Organizations at Student Involvement by no later than Friday 12 noon of the week prior, and give your name, phone number and the name of your organization. Each organization will be permitted one excused absence per semester; additional failure to meet six minimum hours per week will initiate the 3 strike process described above.
8. Staffing the booth means being inside the booth or directly behind the booth.
9. Booths will not have to be staffed on rainy days.
10. Staffing of booths will not be required after the last day of instruction of each semester.

BOOTH REMOVAL

1. The University reserves the right to remove any booth after the approved time period has ended, if an organization places a booth on campus prior to the approved time frame, or if an organization fails to remove the booth after being notified to do so. An attempt will be made to notify the organization by verbal and/or written contact before the booth is removed.
2. Any booth removed by the University will be removed by Plant Operations and disposed of.
3. Any organization which has their booth removed by Plant Operations will be charged a removal fee and will lose their opportunity for a booth space next semester. Any organization that is charged a booth removal fee will automatically be placed on probation and their student organization recognition and benefits will be suspended until the bill has been paid. A receipt showing the bill has been paid must be presented to the Reservation Center to officially be removed from probation.
4. All booths must be removed over the finals and exam prep days, prior to the start of finals.

BOOTH CONSTRUCTION GUIDELINES

1. All booths will be inspected by Risk Management to ensure they are structurally safe.
2. Size of the booth shall be limited to 6' x 8' and 8' high.
3. All wood in contact with ground shall be pressure treated Douglas Fir or Redwood.
4. All headers above opening shall be a minimum of 4 inches by minimum of 1 inch wide per every foot of opening (i.e., 4 feet opening shall be 4 x 4, 6 feet opening to be 4 x 6, etc.).
5. Plywood siding and roof sheathing shall be 1/2" thick minimum. Grade shall be exterior grade CDX or better; edges of plywood shall be trimmed.
6. All nailing shall be per table No. 25-Q or U.B.C.
7. Lumber sizes:
 - ceiling and rafter joists shall be minimum 2 x 4 @ 24" O.C.,
 - studs shall be minimum of 2 x 4 @ 24" O.C.
8. All structural connections without plywood sheathing shall be fastened with aid of metal connectors.
9. There shall be no overhang obstructions for at least 80 inches above walking surface.
10. Building shall not have any protruding objects greater than 12" maximum.
11. Counter or service opening shall be no higher than 48".

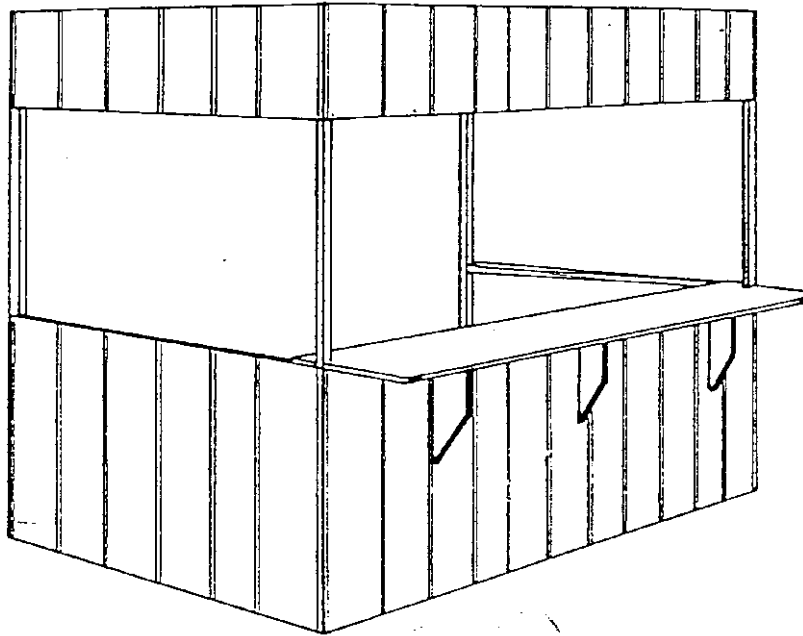

TYPICAL BOOTH PLAN

BOOTH MATERIAL LIST

- (3) 4' x 8' x 1/2" or 5/8" sheets of exterior plywood (T1-22 siding)
- (1) 1" x 12" x 8' Pine
- (1) 2" x 8" x 8' Douglas Fir
- (13) 2" x 2" x 8' Douglas Fir
- (1) 1" x 6" x 8' Douglas Fir or Pine
- (1) 2" x 4" x 8' Douglas Fir

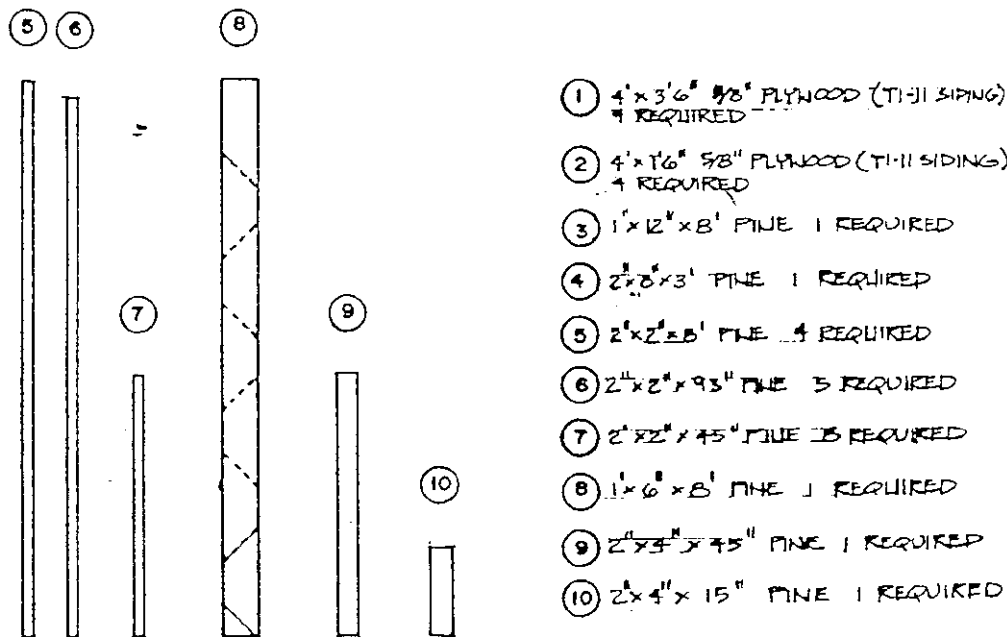
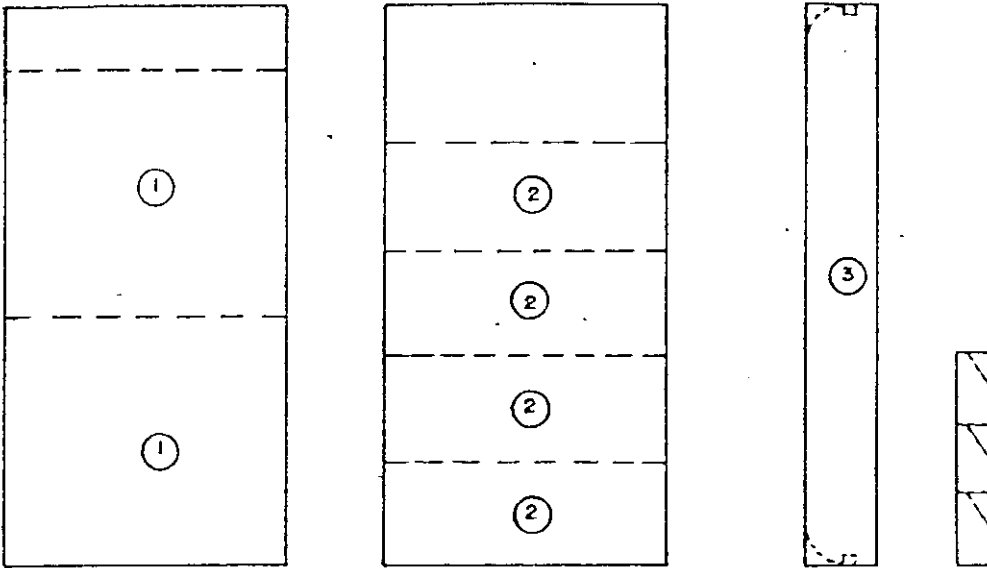

BOOTH BUILDING INSTRUCTIONS

1. Lay out plywood sheets No. 1 (as shown on Fig. 1). Nail the 2 x 2's No. 6 and the 2 x 4 No. 9 to the plywood sheets No. 1.
2. Lay out plywood sheets No. 2 (as shown on Fig. 2). Nail the 2 x 2's No. 6 and the 2 x 4 No. 10 to the plywood sheets No. 2.
3. Lay out plywood sheets No. 1 and 2 (as shown on Fig. 3). Nail 2 x 2's No. 5 and No. 7 as shown. Construct the two sides (Fig. 3).
4. Connect the front (Fit. 1) to the two sides (Fig. 3).
5. Add the bracing No. 8 to the bottom corners as shown on Fig. 5.
6. Connect the top front (Fig. 2) to the two sides and connect the back brace No. 6 to the two sides. Brace the corners as shown in Fig. 4 using braces No. 8.
7. Connect shelf top and shelf bracing as shown on cover sheet.

**FIGURE
1**

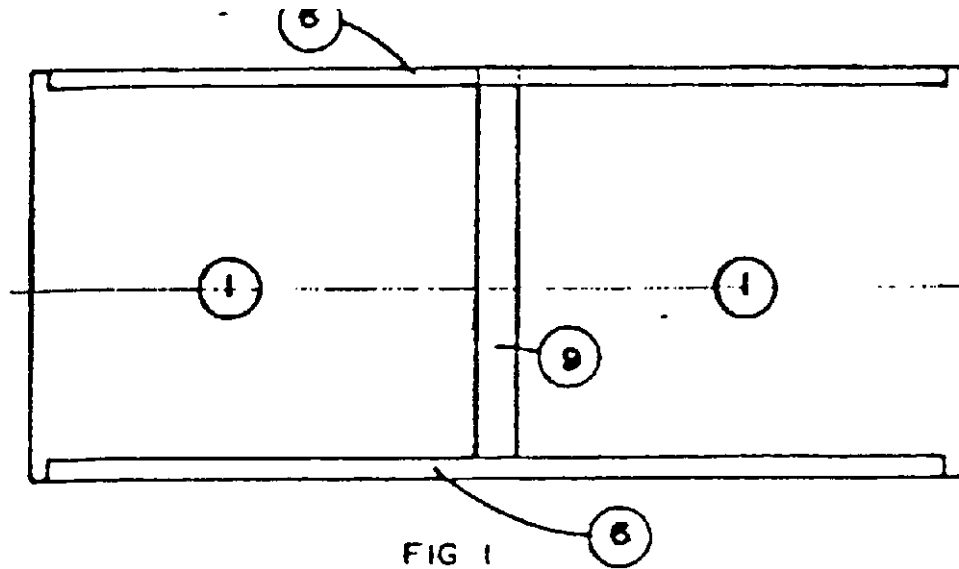

**FIGURE
2**

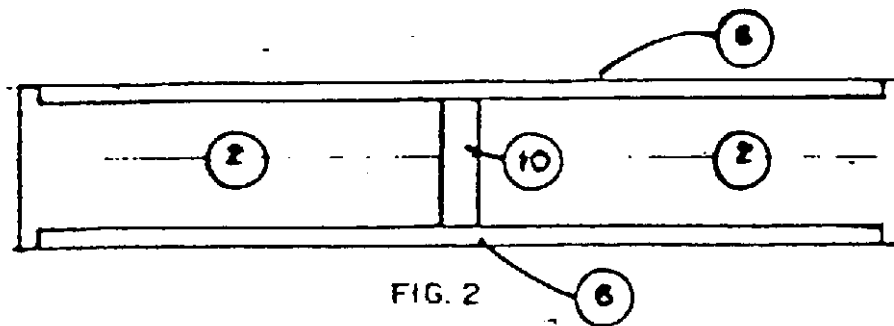

**FIGURE
3**

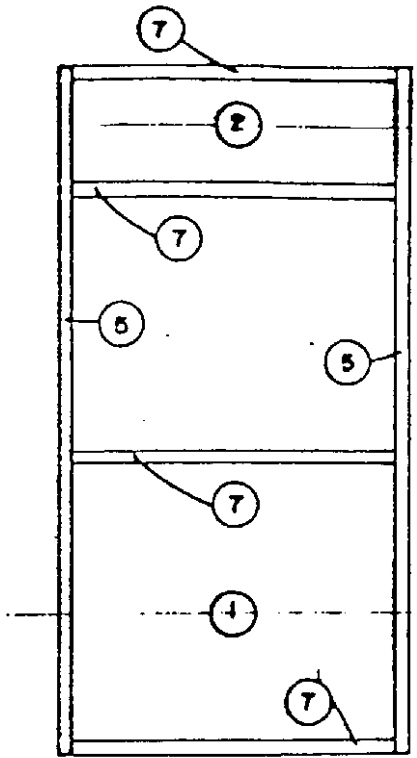

FIG. 3

**FIGURE
4**

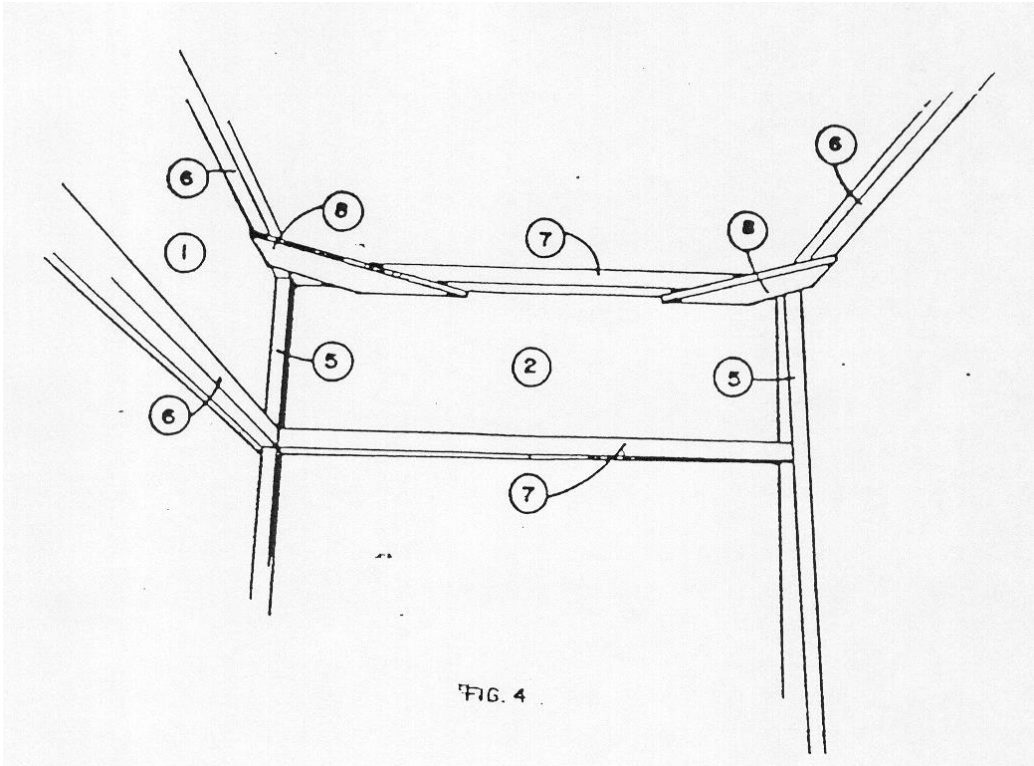
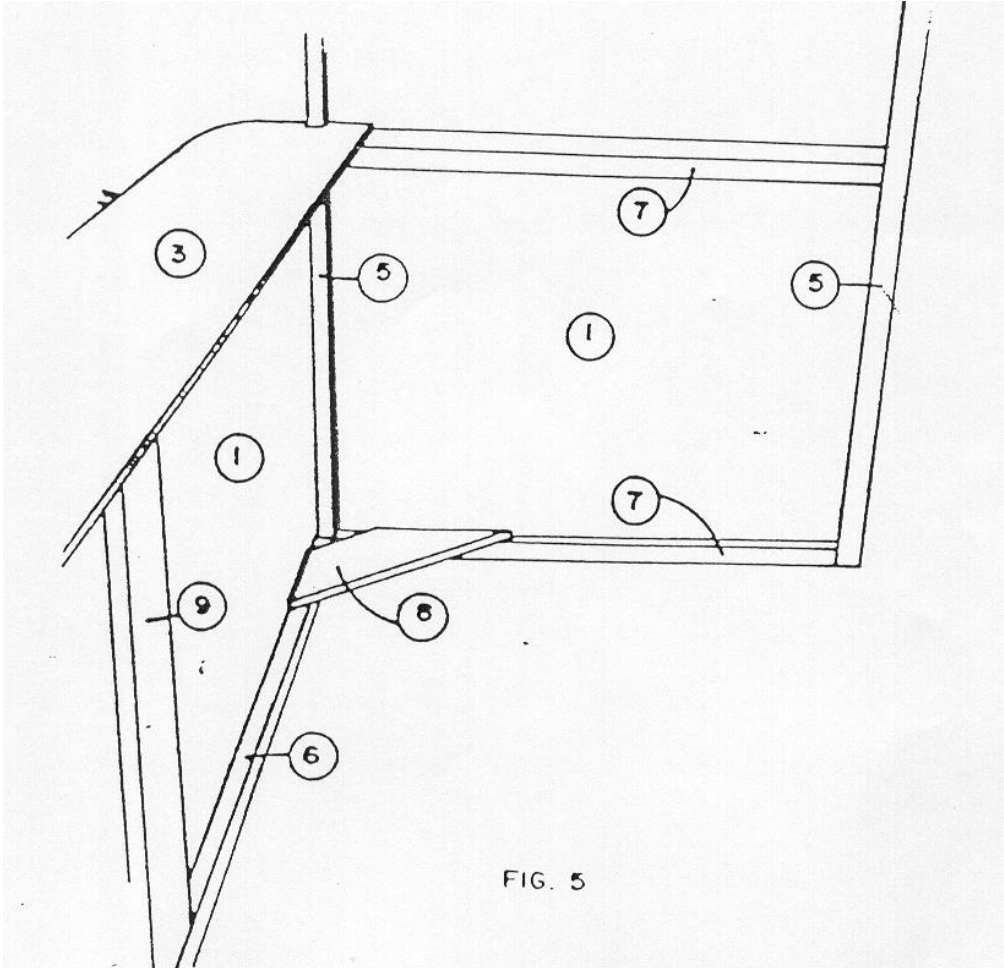

FIG. 4

**FIGURE
5**



Revised: 9.15.2015

Student Involvement, USU Room 306 *(559) 278-2741
Reservation Center USU, Room 301 * (559) 278-6024